

# PANORAMA™ Sensifier™\*

\*Sensifier™: "A medium which creates a realistic virtual environment by projecting multiple sensual stimuli."

For many years, the effectiveness of promoting products and services with bright and dynamic backlit images has been well known and documented. New in this millennium, **PANORAMA™** by Clearr Corporation has made this medium even more appealing, realistic and eye catching, through the use of convex-face image presentation and minimized structural framework. The convex faces allow viewing even from the most oblique angles, and the minimal structural elements help focus viewers' attention on the graphic messages.

Now Clearr expands your promotional horizons abundantly by introducing **PANORAMA™ Sensifier™**. It creates a complete virtual environment by combining the alluring elements of sight, smell and sound† into one attractive display unit.

Sight and sound modules are conveniently hidden behind an integrated, easily-removed opaque ventilation panel. Aroma and sound elements are quickly inserted and changed. Sound may be continuous, or may be configured to play only when nearby motion is detected, or when a button is pushed.

The effectiveness of appealing to each of the three critical senses separately is powerful by itself. Appealing to them collectively, through a single efficient and attractive display unit, opens up new worlds of possibilities for powerful and provocative promotion of your products and services.

†If preferred, units are available without a smell or sound module.



Hundreds of distinct floral scents are available to achieve just the right mood or environment. The scent module is located in the bottom compartment on this double-sided floor-mount unit. The module is easily accessed by removing the opaque ventilation panel.

The availability of more than forty separate coffee scents (and over 33,000 other scents) makes extremely specialized product promotion possible. This two-image, single-sided wall-mount unit may be positioned either vertically or horizontally.

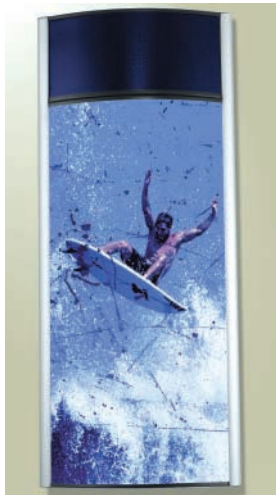

Several versions of ocean-surf scents are available to "virtually" bring the sea into the store. A realistic "surf" sound completes a total sight-scent-sound sensory trilogy. This single-sided wall-mount unit may be positioned either vertically or horizontally. The sensory-module compartment may be placed at the top, as shown, or on the bottom, or in the case of horizontal placement, at either end.



The removable scent module accepts small replaceable scent elements, which provide 200-250 hours of scent dispersion each. The module heats the gel elements, and disperses the scent with a powerful built-in fan. A separate integral sound module (not pictured) is also available.

The scent module has separate controls for heat intensity and fan speed, to control the dispersion of the scent. A scent element is shown opened in front of the unit—in use it is placed inside the scent module.

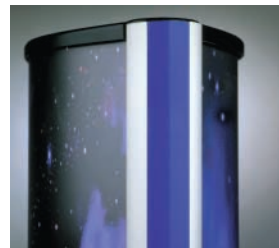

The side supports consist of an anchor post (blue in photo) and the frame section(s)—there are two frame sections on each side on double-faced models. The standard finish for both the anchor post and frame sections is satin-anodized aluminum, but one or both components may be painted or anodized a wide variety of colors, yielding custom one- or two-tone finishes. A two-tone example is pictured.



PANORAMA™'s side support assemblies hinge open, without tools, for immediate access to the graphic and the protective cover sheet. When necessary, the cover panels may be removed in a matter of seconds, to access the lighting and/or sensory components.



Clearr Corporation, Display Division • 6325 Sandburg Road • Minneapolis, MN 55427, USA  
763/398-5400 • Fax: 763/398-0134 • info@clearrcorp.com • www.clearrcorp.com

call toll-free

**800/LITEBOX**

(800/548-3269)

PANORAMA™ Sensifier™  
Virtual-Environment  
Backlit Displays

### Single-image Wall-mount Model

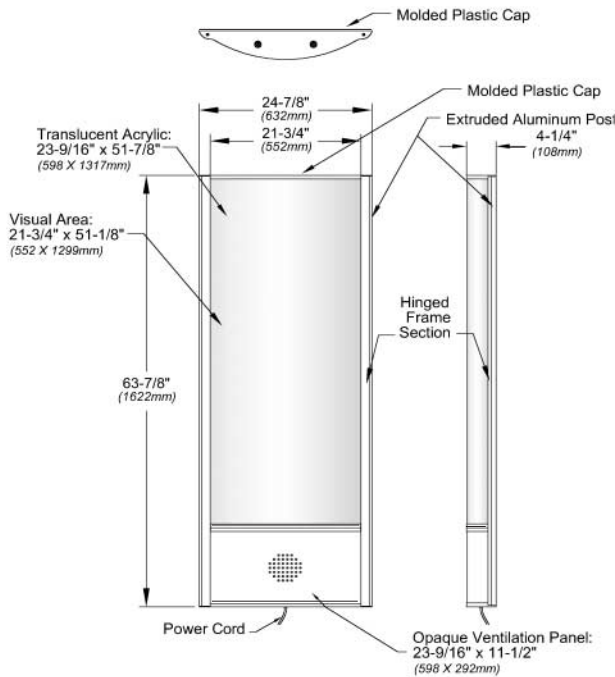

### Double-sided Floor-mount Model

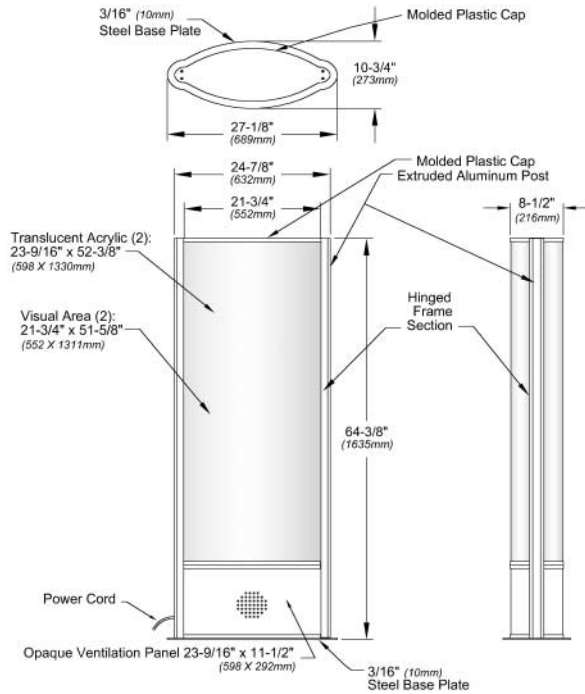

### Two-image Wall-mount Model

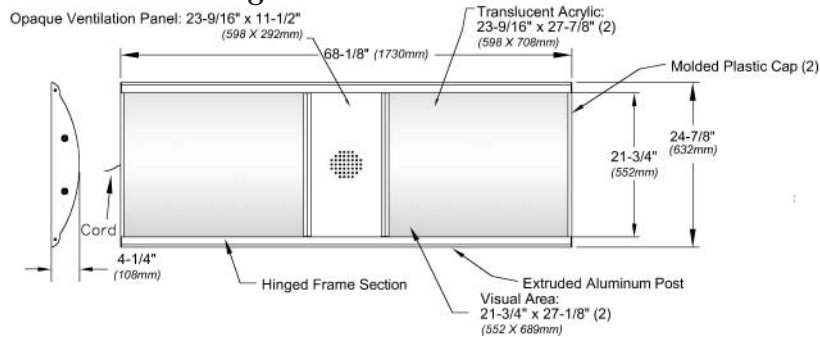

A selection of more than 33,000 distinct scents is available. A few of the most popular scents are listed below. In addition, custom scents may be produced for a nominal fee.

#### Florals & Aromatics

Code	Scent	Code	Scent
112	Cherry Blossom Time	008	Cedar Chest
014	Eucalyptus Breeze	019	Whispers of Wisteria
107	Wedding Flower	022	Jazz-mine
023	Luxurious Lavender	053	Oriental Ginger Lily
082	Sahara Sandalwood	049	Oh So Rosey
113	Rocky Mountain Springtime	118	Hibiscus Mango

#### Seasonals

Code	Scent
098	Cinnamon Apple
021	Newly-mown Lawn
093	Softly Musk
002	Christmas Spruce

#### Fresh & Natural

Code	Scent	Code	Scent
033	April Showers	109	Sparkling Fresh
104	New Car	025	Leathersmith
108	Sea Spray	037	Rainforest Mist
039	High Tide	057	Pacific Breeze
069	Clean & Pressed		

#### Edibles

Code	Scent	Code	Scent
003	Apple Tart	006	Bubble Gum
007	Cappuccino Java	044	Choco-lot
058	Chocolate Cookies	009	Chocolate Delight
011	Coconutty	050	Coffee Mocha
013	Confectionery Shop	086	Oven-baked Rolls
088	Viennese Roast	010	Citrus Fusion
116	Chocolate Hazelnut	026	Tropical Fruit Medley
036	Pink Grapefruit	085	Popcorn at the Cinema
117	Chocolate Raspberry	028	Mint Everest
041	Warm Vanilla	087	Grandma's Kitchen
100	Watermelon Time	111	Gingerbread Man
060	Smokin' on the Grill	114	Country Peach Cobbler
118	Coffee Crumb Cake		

#### Mood Therapeutics

Code	Scent	Description
077	Après le Bain	The feeling of relaxation after a luxurious bath.
073	Clarity	A sophisticated scent that helps focus the mind.
074	Sun Up	A morning walk through a citrus grove, stimulating and awakening.
076	Evening	An exciting blend of ingredients to get ready for a night on the town.
075	High Chaparral	An introspective scent reminiscent of spring on the High Plains.

**PANORAMA™ Sensifier™**  
**Virtual-Environment Backlit Displays**